

MAASDAM POWERLIFT™

OPERATION & SAFETY MANUAL

3 TON (6,000 LBS.) SUV JACK WITH FOOT PUMP

1-888-797-7855

MAASDAM.COM

Meets ASME/2005 ANSI standard requirements

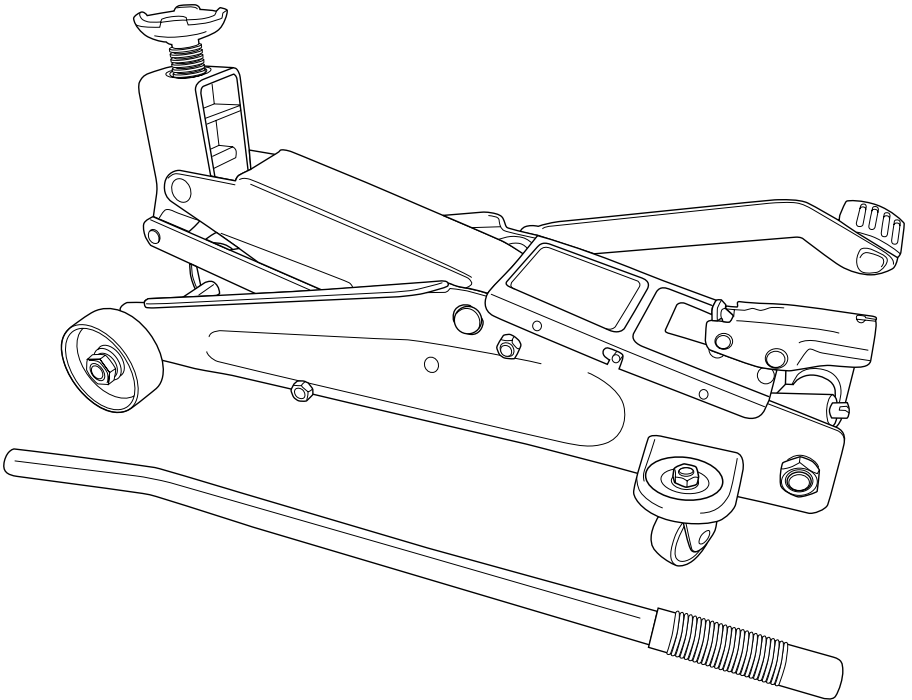

Table of Contents

Safety Information	2	Maintenance	6
Warranty.....	3	To Add Hydraulic Jack Oil	6
Pre-Operation.....	3	To Replace Hydraulic Jack Oil	6
Before Assembly and Operation	3	Lubrication	6
Specifications.....	3	Storing.....	6
Part Number Key.....	4	Rust Prevention	6
Operating Instructions.....	5	Troubleshooting	7
How It Works	5		
Handle Attachment.....	5		
Purging Air From Hydraulic System	5		
To Raise and Lower the Vehicle.....	5		

Safety Instructions

READ AND SAVE THESE INSTRUCTIONS

- Study, understand and follow all instructions before operating this device. Do not exceed rated capacity. Use only on hard level surfaces capable of supporting the load.
- This is a lifting device only. Immediately after lifting, support the vehicle with appropriate means.
- Do not move or dolly the vehicle while on the jack. Lift vehicle only in areas specified by the vehicle manufacturer.
- No alterations shall be made to this product.
- Do not use jack in adverse or extreme weather conditions, in strong magnetic fields, in windy conditions, or on uneven or unstable ground.
- Use of the floor jack near static electricity is not recommended.
- Do not handle loads that might lead to dangerous situations (For example: acids, radioactive material, brittle or fragile loads).
- Instructions, safety information, and safe operating procedures must be communicated in the owner/operator's native language and be understood prior to authorized use. Make sure the owner/operator is fully aware of safe use and inherent dangers associated with this product.

- Dispose of used hydraulic jack oil in accordance with local regulations.
- Clear the area of bystanders, especially small children, tools or other objects before using.
- Lifting of people with the floor jack is prohibited.
- Do not use floor jack in direct contact with food or food ingredients.
- Use of floor jack on sea vessels is prohibited.
- Inspect jack prior to each use. Do not attempt use if the unit is broken, bent, cracked, or has missing and/or damaged parts. Replace broken, bent, cracked, missing and/or damaged parts, and/or missing labels, warnings and/or decals with factory authorized parts prior to use.
- Any jack that appears to be damaged or has worn parts should be removed from service immediately.
- For your safety and to prevent injury use service jack for lifting purposes only.
- Always support vehicle with jack stands.
- Failure to heed these warnings may result in personal injury and/or property damage.



CAUTION: Read, understand and follow all Safety Rules and Operating Instructions in this manual before using this product.

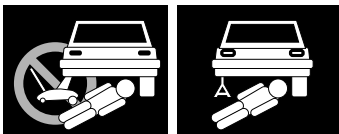

This jack is a lifting device only. It is not a support device. **NEVER** place yourself under or near a raised vehicle supported by a jack, immediately after lifting, support vehicle with jack stands or other appropriate means. **DO NOT** move or dolly the vehicle while it is on the jack.

Warranty

Maasdam Pow'R Lift™ (the "Manufacturer") proudly warrants these quality manufactured products only to be free from defects in workmanship and factory materials so long as the tool is used and maintained properly and in accordance with the Operations and Safety Manual and information which accompany and relate to the tool. Products made for Maasdam Pow'R Lift™ outside the USA are covered by other limited warranties as stated on the box for the particular product.

Manufacturer shall have the sole discretion to inspect and determine whether purchaser has used and maintained the tool properly for purposes of application of this warranty. The sole monetary limit and measure of damages of Manufacturer shall be the price of the defective unit, and Manufacturer shall have no liability or responsibility for consequential or any other kind of damage caused by the defective unit or any of its parts, including, but not limited to, loss of use, commercial loss or loss of business. This warranty is extended only to the first purchaser of this product and only if the product is used as intended by the Manufacturer.

To use this warranty, you may bring the defective unit to the store from which you purchased it, or you may return the tool to our factory at 415 East State Parkway, Schaumburg, IL 60173, postage prepaid. Before returning the product to our factory, call the office using our toll free telephone number, 888-797-7855, to identify the defect(s) of which you complain. Your return address should appear on the shipping container when transmitting any tools.

THIS WARRANTY IS IN PLACE AND IN LIEU OF ALL WARRANTIES OF MERCHANTABILITY AND FITNESS. By acceptance of the product, the purchaser and user agree to the terms hereof and incorporate the same in any contract for the purchase of this product.



WARNING: This product can expose you to di(2-ethylhexyl) phthalate (DEHP), which is known to the State of California to cause cancer and birth defects or other reproductive harm. For more information go to www.P65Warnings.ca.gov.

Pre-Operation

BEFORE ASSEMBLY AND OPERATION

Compare all parts with the Package Contents lists in this manual. If any part appears missing or damaged, do not use this product. Contact the Customer Service at 1-888-797-7855 or visit www.maasdam.com.

SPECIFICATIONS

Model	Jack Dimensions	Max Load Capacity	Lifting Range	Saddle Dimensions	Jack Weight
3 Ton SUV Jack	25 in. x 10 in. x 7.5 in.	6,000 lbs	7.5 to 21 in.	2.28 in. Diameter	45 lbs.

Part Number Key

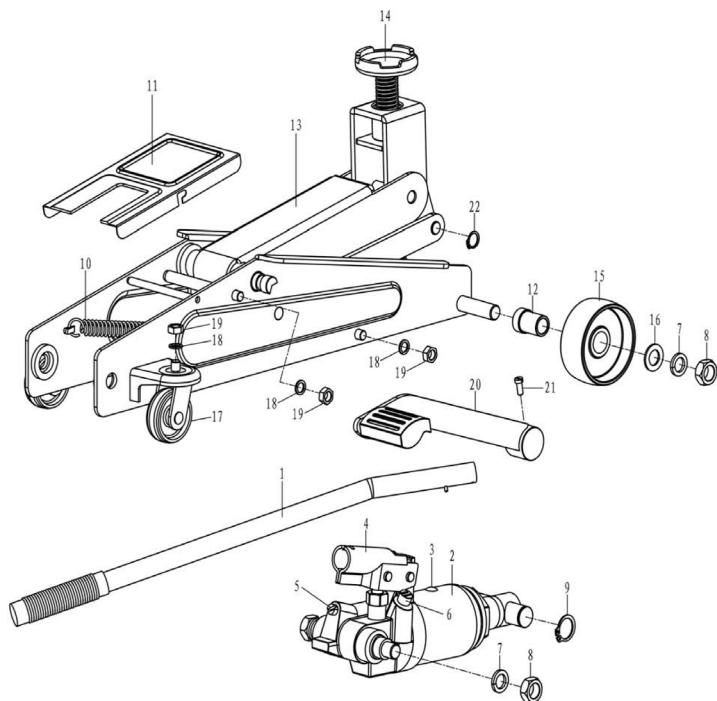

Part	Description	Part	Description
1	Handle	12	Spacer Front Wheel
2	Hydraulic Ram	13	Lifting Arm
3	Oil Fill Plug	14	Saddle
4	Handle Bracket	15	Front Wheel
5	Release Valve	16	Flat Washer $\varnothing 16$
6	Overload Value	17	Caster
7	Spring Washer $\varnothing 16$	18	Spring Washer $\varnothing 10$
8	Nut M16	19	Nut M10
9	Snap Ring "C" -1	20	Foot Pedal
10	Spring	21	Screw M6 X 15
11	Cover Plate	22	Snap Ring "C" -2

Operating Instructions

HOW IT WORKS

- The jack power unit consists of plunger, plunger cavity, hydraulic oil reservoir, cylinder and ram.
- An upward stroke of the jack handle draws oil from the reservoir into the plunger cavity. Hydraulic pressure closes a valve that keeps oil in the cavity.
- A downward stroke of the jack handle forces oil into the cylinder, pushing out the ram and raising the saddle.



NOTE: As a protective feature, when the ram reaches maximum extension, sufficient oil passes back into the reservoir to prevent an overextended ram stroke and possible jack damage.

- When the release valve is open, oil flows back into the reservoir, causing the ram to retract, lowering the saddle.

Handle Attachment

TO ATTACH HANDLE (SEE FIG.1)

1. Insert lower handle into handle socket.
2. Remove handle fix bolt from upper handle

Purging Air From Hydraulic System

3 TON SUV JACK (MODEL MPL1449-HD)

- Turn release valve counter-clockwise with handle no more than two full turns.
- Remove oil fill plug.
- Pump jack handle quickly in several full strokes.
- Repeat above steps as needed. Remember to replace oil fill plug.

To Raise and Lower the Vehicle

1. Place vehicle in PARK (in gear on standard transmissions) and apply emergency brake.
2. Close the jack release valve by turning the handle clockwise.
3. Block the vehicle wheels for lifting stability
4. Center jack under load so that saddle contacts load firmly and will not slip. (Refer to vehicle manufacturer's owner's manual to locate the approved lifting points on the vehicle.)
5. Pump the jack handle until saddle nears contact with vehicle.
Check to see that the saddle is centered and will contact the lifting point firmly.
6. Continue to pump the jack handle to lift the vehicle to a height slightly above the jack stands or other supports. Then turn the handle very slowly counterclockwise to open the release valve to lower the vehicle onto the supports.



WARNING: To avoid pinching or crushing hands or feet, ALWAYS keep them clear of the jack hinge and ground contact area when lowering the vehicle. The jack is a lifting device only. DO NOT move or dolly the vehicle while it is on the jack.

Maintenance

(See Fig. 1 on pg. 4)

TO ADD HYDRAULIC JACK OIL

With saddle fully lowered and the jack on level ground, unscrew and remove oil fill plug. Using a good grade of SAE 5W hydraulic jack oil, fill the oil reservoir to the bottom of the threads in the oil filler hole. Replace and tighten the oil fill plug.

DO NOT ALLOW dirt or debris to enter the system.

TO REPLACE HYDRAULIC JACK OIL

1. Open the release valve by turning handle counterclockwise. Unscrew and remove oil fill plug.
2. Turn entire jack over so that all of the old oil will drain out of the oil fill hole.



NOTE: When draining oil, use a proper container and **ALWAYS** follow **ALL** local and state waste disposal guidelines.

3. After all of the old oil has drained out of the jack, turn the jack back over to a level position fill with new oil.
4. Rapidly pump jack handle 6 to 8 strokes to release any pressurized air.
5. Using a good grade of SAE 5W hydraulic jack oil, fill the reservoir to the bottom of the threads in the oil fill hole. **DO NOT ALLOW** dirt and debris to enter the system.
6. Replace and tighten oil fill plug.



IMPORTANT: When adding or replacing oil, **ALWAYS** use a good grade of (SAE 5W) hydraulic jack oil. **NEVER** use brake fluid, alcohol, glycerin, detergent motor oil or dirty oil of any kind. Improper oil usage will cause serious internal damage to jack.

LUBRICATION

1. Use a good grade of lubricating oil on all moving parts when needed (arm linkages, front wheels and rear casters).
2. Grease the lifting arm assembly through its grease fitting (see Fig. 1 on page 3), using a good grade of multi-purpose chassis grease.

STORING

When jack is not in use, or when storing the jack, **ALWAYS** have the saddle in its lowest (down) position. It is recommended that the jack be stored in a dry location with all wheels touching the ground on a relatively level surface.

RUST PREVENTION

Check ram and pump piston every two months (or sooner, based on usage) for any signs of rust or corrosion. Clean as needed and wipe down with an oil cloth.

Troubleshooting

Problem	Solution
Jack will not lift load or leaks down excessively	<ul style="list-style-type: none"> <li data-bbox="367 188 1003 289">□ The release valve is not closed. Turn the valve clockwise tightly. If this does not work, remove handle, lubricate handle receptacle and handle end, then retry. Excessive weight - decrease weight or change to higher capacity jack.. <li data-bbox="367 302 1003 354">□ Low on hydraulic fluid. Refill the jack to the correct level of hydraulic fluid. <li data-bbox="367 367 1003 443">□ Pump seals or back-up ring may be defective. Clean hydraulic fluid passages, replace seals and refill hydraulic fluid. (Must be serviced by qualified service center)
Jack will not lift to its full height	<ul style="list-style-type: none"> <li data-bbox="367 451 1003 503">□ Low on hydraulic fluid. Refill the jack to the correct level of hydraulic fluid. <li data-bbox="367 516 1003 570">□ The hydraulic system has trapped air. Open the release valve, pump handle rapidly (4) full strokes to purge air, close release valve.
Jack will not lower completely	<ul style="list-style-type: none"> <li data-bbox="367 578 1003 656">□ Return spring is broken or linkages are binding. Replace spring if broken. Grease pivot shaft and all lift arm linkages. Oil reservoir is overfilled.
Jack will not lift smoothly or jack feels spongy	<ul style="list-style-type: none"> <li data-bbox="367 664 1003 716">□ The hydraulic system has trapped air. Open the release valve, pump handle rapidly (4) full strokes to purge air, close release valve.
Jack will not hold load or handle rises	<ul style="list-style-type: none"> <li data-bbox="367 740 1003 818">□ Discharge ball is not sealing hydraulic system and oil may be dirty. Manually flush hydraulic system. Open the release valve, as required, to raise and lower the lift arm. Manually raise and lower lift arm.



1-888-797-7855

WWW.MAASDAM.COM

Retain this manual for future use.